

Technical Regulations NORDIC EUROPEAN ZONE (NEZ) CROSS KART 2011

Table of content TECHNICAL REGULATIONS (CK-T)

CK-T 0 GENERAL	3
CK-T 0.1 General regulations	3
CK-T0.1.1 General	3
CK-T0.1.2 Exemptions from the regulations	3
CK-T 0.1.3 Photocells.....	3
CK-T 0.1.4 Cylinder capacity	3
CK-T 0.2 Fuel regulations.....	4
CK-T 0.3 Regulations about exhaust noise measurement	4
CK-T 0.4 Common safety regulations.....	4
CK-T 0.4.1 Safety harness	4
CK-T 0.4.1.1 Types	4
CK-T 0.4.1.2 Use.....	4
CK-T 0.4.1.3 Marking of damaged belts, national regulation	5
CK-T 0.5 Scrutineering and technical inspections	5
CK-T 0.5.1 Scrutineering	5
CK-T 0.5.2 Technical inspection.....	6
CK-T 0.6 Driver's personal safety equipment	7
CK-T 0.7 Start number	9
CK-T 0.8 Vehicle identity book	9
CK-T 0.9 Communication	10
CK-T 1 Frame	10
CK-T 1.1 Structural parts and roll cage	10
CK-T 1.2 Floor	11
CK-T 1.4 Protection against wedging under a competitor	11
CK-T 1.5 Towing point.....	12
CK-T 2 Wheels and suspension	12
CK-T 2.1 Tires	12
CK-T 2.2 Suspension	12
CK-T 2.3 Springs, shock absorbers.....	13
CK-T 3 Engine and drivetrain	13
CK-T 3.1 Engine.....	13
CK-T 3.2 Fuel system.....	13
CK-T 3.3 Exhaust system.....	14
CK-T 3.4 Startsystem	14
CK-T 3.5 Cooling system.....	15
CK-T 3.6 Electrical system	15
CK-T 3.7 Power transfer	15
CK-T 4 Brake system.....	16
CK-T 4.1 Foot brake	16
CK-T 5 Steering system.....	16
CK-T 5.1 Steering.....	16
CK-T 6 Bodywork	16
CK-T 6.1 Coverage of chassis.....	16

CK-T 6.3 Seat.....	16
CK-T 6.4 Safety harness	16
CK-T 6.5 Safety net.....	16
CK-T 7 COMMUNICATION	17
CK-T 7.1 Rearview mirrors, lamps, windscreen	17
CK-T 8 INSTRUMENTATION.....	17
CK-T 8.1 Instrumentation, controls	17
CK-T 9 OTHER.....	17
CK-T 9.1 Minimum weight	17
CK-T 9.2 Maximum dimensions.....	18

Technical Regulations NEZ CROSS KART (CK-T)

Application of the technical regulations

When you are reading the technical regulations keep this in mind:
Read the regulations and if it does not specifically state that something is allowed then it means that no changes are allowed from the original specifications.
This means that what is not explicitly allowed is to be considered as banned.

CK-T 0 GENERAL

The NEZ may make exceptions or changes to the regulations during the season if there is a need for it due to safety or any other reason. Where nothing else is stated the same regulations apply to all classes.

CK-T 0.1 General regulations

CK-T0.1.1 General

It is the competitor's responsibility to make sure the car complies with the regulations in full during the entire competition.

CK-T0.1.2 Exemptions from the regulations

ASN permit approvers, event organisers, clerk of the course, judges and technical scrutineers are not allowed to decide about or make exemptions to the NEZ,s sporting- or technical regulations.

CK-T 0.1.3 Photocells

Receivers and photocells and any other electrical equipment shall be placed in areas approved by the circuit inspection or outside the fencing of the circuit.

CK-T 0.1.4 Cylinder capacity

The cylinder capacity is the volume generated when the piston moves up and down. When calculating the cylinder capacity the following formula is used:

$$V = 0.7854 \times d^2 \times x \times n$$

V = volume

d = diameter of cylinder

s = stroke

n = number of cylinders

CK-T 0.2 Fuel regulations

Methanol/E 85

Methanol as well as E 85 is prohibited as fuels during practise and competition in crosskart. In classes up to 125 only 98 unleaded is allowed. **Organizer and / or national federation have the right to demand compitors to use gasoline from a specific reservoir. This can be a specific gas station near race track with specific pump number or a specific tank in paddock. A possible demand shall be written in the supplementary regulations with necessary specifications. In classes 250 and 650 maximum 103 octane is aloud.**

CK-T 0.3 Regulations about exhaust noise measurement

Measurements shall be carried out at a competition to such extent that the prescribed maximum noise level is not exceeded. Measurements take place during practise/competition at the circuit when the car is moving.

Under no circumstances may a car be permitted to start or continue to participate in a competition if the car's exhaust noise level exceeds the maximum level of 100 dB (A).

Measurements shall be carried out with a sound level meter of precision type class 1 or better that meets the requirements in "International Electro technical Commission" publication 651, ("IEC"). Measurements will be carried out with sound level meter in position "SLOW". The sound level meter is to be calibrated before measurement.

CK-T 0.4 Common safety regulations

Safety equipment for all crosskarts (cars) competing in classes that have been approved by NEZ

CK-T 0.4.1 Safety harness

CK-T 0.4.1.1 Types

Minimum requirement is a 4 point harness and no two mounting points may have a common fastener. The mounts shall be well dimensioned and attached securely to the car's space frame (chassis) with min. 8 mm screws with locknut. Safety harness of NASCAR type is permitted.

The safety harness may be shortened after the strapping point however shortened ends must be melted, folded and sewn with suitable thread. - Homologated harnesses are recommended in NEZ competitions.

CK-T 0.4.1.2 Use

The Safety harness must be kept in its homologated version and comply with the manufacturers instructions. Harnesses must be replaced after a severe collision

or if the fabric is damaged, stretched or weakened due to chemicals or sunlight. They must also be replaced if metal parts are deformed or rusty.

CK-T 0.4.1.3 Marking of damaged belts, national regulation

Marking will be done to harnesses that are damaged or worn in such a way that they do not meet the requirements in NEZ safety regulations. The marking will be done on both sides of all harnesses near the buckle, with white paint. Marked equipment may not be used in any motor sport context.

CK-T 0.5 Scrutineering and technical inspections

Before competition, participating cars will undergo scrutineering. The inspection will, apart from the driver's personal equipment, cover specified requirements in the technical regulations and ensure that the components do not have damages that may involve a safety risk. Special attention will be devoted to possible cracks on chassis and roll cage. A car that does not meet the technical requirements or has damages that involves a safety risk for the car's driver or any other driver is not to be permitted to participate in competition.

Drivers are obliged to provide a vehicle identification book (also could be named as "Sporting technical passport")of the car at scrutineering. On the car's roll cage, however not on a detachable bar, at the hood lock mechanism shall the vehicle identification book number be punched on a tube or sheet metal at visible place. Drivers that do not present a valid vehicle identification book or technical passport can be denied to participate in competition.

The vehicle identification book or technical passport should be issued by participator's ASN.

CK-T 0.5.1 Scrutineering

An appropriate place for scrutineering shall exist in or in connection with the pit or the start and finish area. At the NEZ championship competitions shall a weighing unit be available. For measurement of the car's body/chassis shall a balanced flat surface exist which is the only place where measurements can be performed.

The scrutineering can either be conducted as a simplified inspection or as a station system at the inspection place.

If a car is found not to comply with the technical regulations shall the clerk of the course and the technical controller be informed about the condition. Decisions concerning what action to take are made by the competition management.

Fuel testing is included as a part of the scrutineering. If the fuel is deviating from what is allowed shall the driver change fuel, to fuel that is allowed before the start of the competition.

A car may not participate in practise/competition if it has not been approved in scrutineering. Drivers may only enter and scrutineer one car per competition.

Drivers that do not present their car at scrutineering within the prescribed time may be denied to start by the competition management.

Inspection during training/competition will be implemented if a car has a fault/deviation according to the regulations. Such a fault/deviation shall be dealt with before starting again.

CK-T 0.5.2 Technical inspection

General

Post race inspection or random sample inspection during competition is referred to as a technical inspection.

Technical inspection is conducted in order to examine if a participating car meets the technical requirements.

Clerk of the course/competition management or judges makes decisions regarding technical inspections. The decision will be written in the records.

The inspection's implementation

At the technical inspection only concerned officials, concerned driver and the cars mechanic are allowed to participate. The person responsible for the inspection limits the number of participants.

If a car is found deviate from the rules a careful record shall be established that details what the deviation is, used measurement method, used measuring instruments/interpreters, measures and assessed tolerances in the measures and reference to rules/homologations.

Is the post race inspection caused by a protest shall only those parts specified in the protest be checked. Records shall be established in this case irrespective of results.

For fuel inspections see "Manual for fuel samples" on NEZ homepage. As selection instrument the Digatron DT-47 FTD may be used (manual exists on NEZ: s homepage, Karting– rules). Technical controller also has the possibility to take samples and if the result deviates from the approved values measures will be taken.

A copy of the record is given immediately to the competitor and the person who decided about the inspection. The original is retained by the organizer.

Later performed inspection

If the inspection can not be completed immediately, the car as a whole or parts of it, may be retained during a reasonable time by those that will carry out the inspection. If deemed appropriate parts may be sealed awaiting a final inspection.

The competitor is obliged to organise personnel and equipment that is needed in order to achieve the aim with the inspection. Concerned competitor and mechanic shall be allowed to participate in the inspection.

Further measures, penalty

The person who decided about the inspection decides on the basis of the result about further measures.

Competitors who do not follow decisions about technical inspection will be disqualified and to be reported to his/her national ASN for punishment.

Records and the decisions concerning penalties will be enclosed in the competition report.

Compensation of costs

No compensation is made for refitting of parts at a technical inspection.

If the decision about a technical inspection was based on a protest from a co-competitor, and no technical faults are established, the co-competitor pays the refitting, however no more than what a corresponding standard part costs to assemble at an authorised brand workshop.

The competitor is responsible for possible costs for transportation of the car if the control is implemented at a later occasion.

If it is established that the fuel is not approved at a fuel analysis the competitor pays the cost for analysis.

CK-T 0.6 Driver's personal safety equipment

Below stated personal security equipment that is the mandatory minimum requirement at practise/competition.

Fire retardant overall

Shoes

Gloves

Balaclava

Neck brace

Helmet

Protective eyewear

Fire retardant overall

At NEZ competitions the overall must be homologated and approved by FIA according to the FIA 1986 or 8856-2000 standards. The labelling for FIA-homologation shall be embroidered on the outside of the collar's back and to include the manufacturer's name.

CIK-approved overall, applies only for 125 cc drivers, must be complemented with NOMEX underwear.

For all overalls applies that these are designed and sewn so that they protect the entire body including neck, ankles and wrists. The overall may not be a two-piece type.

Fire retardant underwear

Underwear made of NOMEX, or cotton, is recommended. Nylon or corresponding materials are prohibited. In case of using CIK-approved overall in class 125 cc, NOMEX underwear is mandatory.

Fire retardant socks

Must be made of the same material as the underwear.

Shoes

Must be made of fire retardant materials and shall protect the entire foot including the ankle (boot type). The sole on the shoe must be made of leather.

Gloves

Must be made of fire retardant materials, type NOMEX, and cover wrists and overlap the overall's sleeve.

Balaclava

Must be made of fire retardant materials, type NOMEX, and cover central and back of the head entirely and overlap other equipment.

Neck brace

Mandatory. Shall be used both during practise and competition.

Helmet

Full face helmet with either face mask or integral protection fastened on the helmet that is protection for the driver's teeth. Protective eye wear of type motocross with roll-off plastic, shall be used. Those helmet weights that are stated below shall be the total weight, which includes all type of extra equipment on the helmet as visors, protection glasses, integral protections etc.

Driver weight under 80kg = max 1350g helmet



Driver weight above 80kg = max 1500g helmet







Helmets should apply to following standards:

FEDERATION INTERNATIONALE DU SPORT AUTOMOBILE
CASQUES DE SECURITE POUR EPREUVES INTERNATIONALES
SAFETY HELMETS FOR INTERNATIONAL MOTOR SPORT EVENTS

Les casques homologués aux normes approuvées par la FIA (voir Annexes 1, 2, 3, Chapitre III) doivent être identifiés par l'une des étiquettes ci-dessous, jusqu'à nouvel avis (les copies sont réelles).
 NB : Ces étiquettes sont des **exemplaires** ; les numéros de série sont différents selon les modèles.

Helmets homologated to one of the FIA approved standards (see Appendix « 1 », Chapter III), must be identified by one of the labels below, until further notice (actual size).
 NB : these labels are **examples** only ; serial numbers are different for each model.

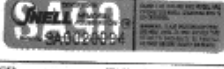
NORME / Standard	ETIQUETTE / Label	REMARQUES / Remarks
SIS 88.24.11 (2) (SWEDEN) — DS 2124.1 (DENMARK) — SFS 3653 (FINLAND)		<ul style="list-style-type: none"> • Etiquette en tissu / Fabric label • Couleur noir ou bleu sur blanc / Colour black or blue on white • Numéro fabricant et spécification selon modèle / Number, make and specifications according to model
DNV/ONK (GERMANY)		<ul style="list-style-type: none"> • Auto-collant / Sticker • Auto-collant / Sticker

B.S.I. (G. BRITAIN) — BS 6658-85 TYPE A		• Auto-collant / Sticker
— BS 6658-85 TYPE A/R		• Auto-collant / Sticker
— BS 2495.77 INCLUDING AMENDMENT 5 (AMENDMENT 5 INCLUS)		• Auto-collant / Sticker
SNELL FOUNDATION (USA)		
— SA 85		• Auto-collant / Sticker
— M 85		• Auto-collant / Sticker
— SA 90		• Auto-collant / Sticker
AFNOR (FRANCE)		
— NF 5 72 305		• Etiquette en tissu / Fabric label
C.E.E./E.E.C. (EUROPE)		
— E 22 AVEC AMENDEMENTS DE LA SERIE « 02 » OU « 03 » / WITH « 02 » OR « 03 » SERIES AMENDMENTS		<ul style="list-style-type: none"> • Numéro inscrit change selon pays d'homologation / Number in circle changes according to country where homologated • N° d'homologation doit commencer « 02 » ou « 03 », suivi du numéro de série / Homologation n° beginning « 02 » or « 03 », followed by production number

Common regulations for marking of damaged helmets.

Helmets that are damaged or worn in such ways that they no longer meet the requirements of NEZ safety regulations will be marked. The marking will be done on helmets on both sides of the chinstrap. White paint (improvement paint) will be used.
N.B.! Marked equipment may not be used in any motor sport context.

CK-T 0.7 Start number

Allocated start number shall be placed on the roll cage's/body's upper rear part, alternatively on the top of roll cage/body. The number shall be easily visible from the sides. A number is also recommended on the body in front of the driver, visible from the front. The following background colour applies for the number: white background minimum 200x200mm. The figures shall be black and the minimum height is 17 cm and the figures minimum width is 3 cm. **Participation in NEZ Championship demand using start number assigned from the Swedish Federation SBF by Håkan Persson. Tlf +46768012665 or email: hakan.persson.1@hotmail.com**

CK-T 0.8 Vehicle identity book

See CK-T 0.5

CK-T 0.9 Communication

All wireless communication between drivers/competition vehicles and pit/competition area, and associated equipment, is prohibited during practise and competition.

CK-T 1 Frame

CK-T 1.1 Structural parts and roll cage

The chassis shall be constructed as a space frame structure comprising welded round and/or square precision steel tubes of type DIN 2391, DIN 2394 or DIN 2395. The roll cage shall be included as a part of the chassis (see fig. 1).

Structural parts of the chassis shall be made of min. 30x2 mm (round tubes) or 30x30x2 mm (square tubes), where no other is stated.

Main roll hoop shall be made in one-piece of round steel tube with minimum dimensions 30x2 mm. The roll cage must be equipped with two forward going braces and two backward going braces made of round steel tubes with minimum dimension 25x2 mm.

In case where the backward going brace is longer than 300mm measured horizontally between the "main roll-hoop" and "rear upper transverse tube" a tube 25x2 shall be welded between these braces. Max distance from head roll hoop 300mm.. Recommended is a continuing of this tube on each side down to the head tube.

Both forward braces must be able to open as a whole, from bottom position and up with a centre lock in the front. The upper joint must include bolt and nut or pin of aeroplane type. Locking and opening of braces shall be possible without any tools needed. The distance between front- or rear braces may not exceed 300 mm. At the height of the drivers head between the rear braces and the main roll hoop there must be a tube (25x2 mm), which protects if the car is hit from the rear or any of the sides. From the main roll hoop to the front braces on both sides a tube must prevent another cars' wheels to reach the cockpit (sees fig. 1).

Between the lower and upper chassis framework a stress relief tube with minimum dimensions 25x2 mm must be mounted. The stress relief tube shall be placed so that they constitute a part of the chassis' framework.

The lower chassis' framework may comprise of tubes in minimum dimension 25x25x2 mm (square tubes) or 30x2 mm (round tubes).

Tubes that are within the head's impact area must be equipped with an energy absorbing material. Minimum thickness must be 12mm.

Welding and tube bending must be done in a professional manner.

No parts of the chassis is aloud outside the wheels outer limit (applies even if the maximum are not used). The chassis may not have any sharp edges or to be designed so that unnecessary damage can be caused to co-competitors' cars.

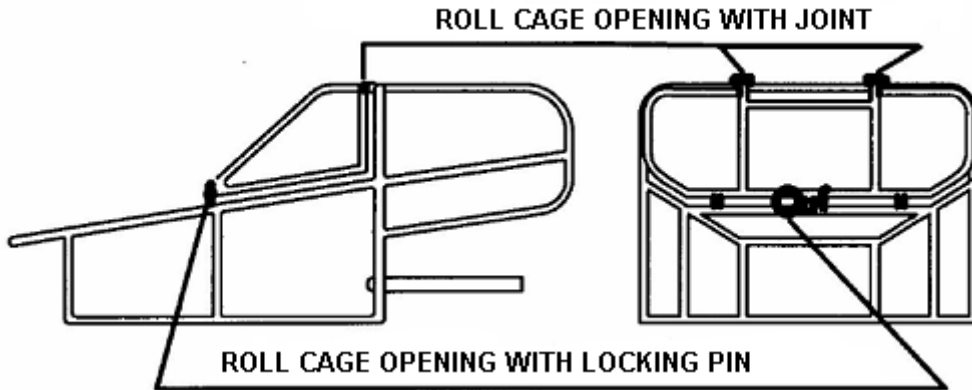

Fig 1. Roll cage seen from the side and the front.

CK-T 1.2 Floor

The car must be equipped with full floor that covers the driver's legs and the driver's seat from beneath. Materials to be used: steel sheet minimum 2 mm thickness or aluminium sheet minimum 3 mm thickness (see fig. 2). The floor must be bolted to the chassis.

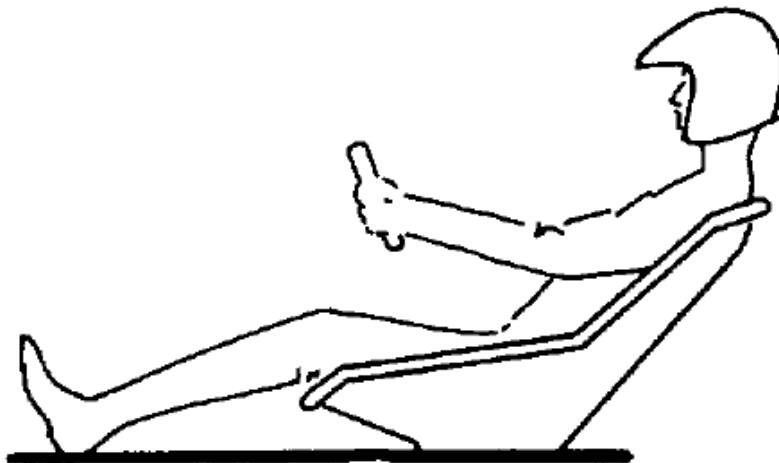

Fig 2. Full floor beneath the driver.

CK-T 1.4 Protection against wedging under a competitor

Between the rear wheels tubes must be mounted so as to prevent co-competitors front wheels from damaging the driver's seat. Tubes must be mounted to the frame (chassis) with a maximum 300 mm vertically or 150 mm laterally between the tubes.

CK-T 1.5 Towing point

A towing point must be placed at/on the side of the front. Minimum diameter of the loop is 30 mm. The towing point may not reach in front of the front wheel pair. The loop must be painted in a different colour.

CK-T 2 Wheels and suspension

CK-T 2.1 Tires

A crosskart shall be equipped with 4 wheels. The wheel rims shall be in steel or aluminium and have a minimum width of 8" in rear and 5" in front, beyond that free. No part of tread may be worn so that the pattern is not visible. All types of pattern cutting is not allowed.

Following tires can be used in all classes:

Rear: Maxxis 225/40-10 32N C9273

Front: Maxxis 165/70-10 27N C9272

Following tires can be used in the class 250cc and above:

Rear: Goldspeed 225/40-10 32N C9203 397

Front: Goldspeed 165/70-10 27N C9205 397

Following tyre treatment is not allowed:

- A. Warming the tyres with any external source like cabinet, heating lamp or electric belt.
- B. Feed the tyre surface with any kind of fluid which give more or less grip.
- C. All kind of tyre cleaning after leaving competitors paddock location
- D. Covering the tyre surface under transport.
- D. Lifting up wheels up from ground under transport

CK-T 2.2 Suspension

The linkage between frame and wheels for the front - and rear suspension is free. The rear suspension must be designed as a unit, i.e. both arms may not move independently (see fig. 4 and 5). The front suspension is recommended with double front link arms.

See also CK-T 3.7 second paragraph. No parts may be produced in any other material than steel/iron.

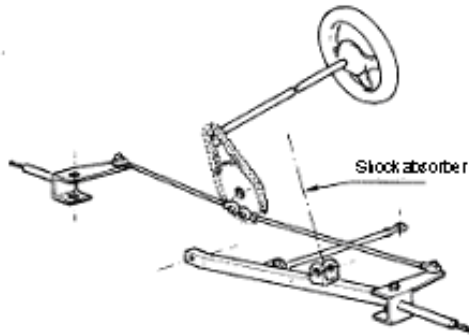

Fig 4. Design example of steering and front suspension.

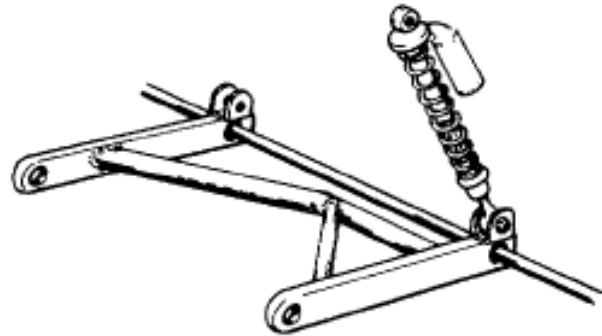

Fig 5. Example of a rear suspension (link with braces, spring and damper)

CK-T 2.3 Springs, shock absorbers

Must exist. The design is free. A stop between the rear suspension and framework must exist so as to prevent the suspension to hit the driver's seat in case of suspension failure.

CK-T 3 Engine and drive train

CK-T 3.1 Engine

The crankcase with, the gearbox integrated, shall come from a serial production motorcycle, karting or ATV engine. Placed on the right or left side. Only 1-cylinder engines are allowed.

Tuning and processing of the engine is free except in 85cc class. No supercharging. Carburettor is free except in 125 class where maximum diameter is 39mm. Sleeve valve engines are not allowed. Fuel injection of mechanical or other model is not allowed. Electronic fuel injection is allowed in class 650 cc.

In the 85 class no tuning is allowed. Engine, electronic and exhaust system shall be original. Transmission for maximum 80 km/h speed

Cylinder capacity may not exceed:

- a) with two-stroke engine 85cm³
- b) with two-stroke engine 128 cm³
- c) with two-stroke engine 255 cm³
- d) with four-stroke engine 660 cm³

CK-T 3.2 Fuel system

The fuel tank must be made of metal or moulding plastic, and mounted in and protected by the chassis. It may not be mounted to the car's floors. If a plastic tank is used it shall be manufactured for such use (e.g. carting). The filler cap must seal tight. Fuel tank ventilation must be arranged so that petrol does not spill out if the car

flips over. A fuel valve must exist. A compensation canister holding maximum 1 dl may be placed beside the carburettor. Fuel lines must be of Nitril-type, not PVC, and be fastened and placed in such way that damages are avoided.

CK-T 3.3 Exhaust system

The exhaust system with muffler must exist, however does not need to be the engine's original system. Exemption is in 85 class where only original is aloud

The last part of outlet shall point down to ground as vertical as possible. A line between the pipe front and rear outlet shall be minimum 20mm under the inner pipes lowest level and maximum 20 degrees from horisontal level.

Exhausts with mufflers may not end in front of a line drawn across the car through driver seat's most rear part and may only extend 10 cm, only the exhaust tail pipe, behind the car's rear restriction line. If the exhaust system is drawn through the cockpit it must be isolated.

An organiser may, if the competition is done during special circumstances, impose in the competition invitation that a lower noise level than 100 dB (A) will apply.

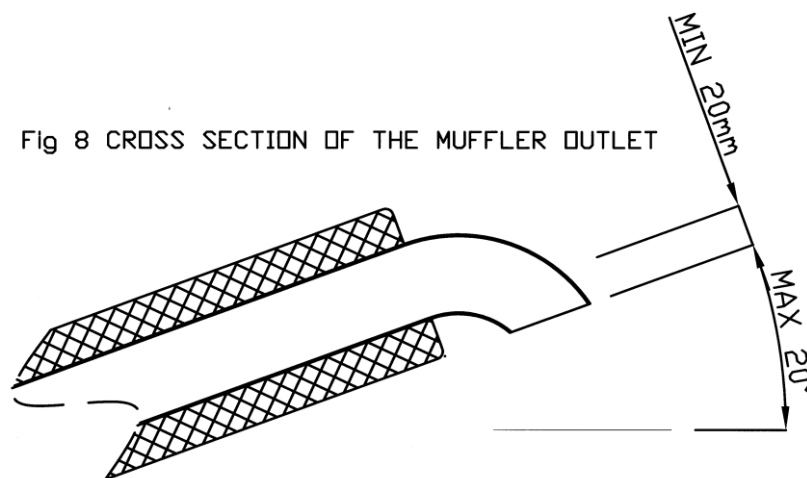

Fig 8. The muffler's outlet.

CK-T 3.4 Start system

Only engines with original starting systems as kick/electrical start are approved.

CK-T 3.5 Cooling system

Unrestricted, however the radiator, hoses etc. must be drawn and mounted in such a way that damage is avoided. The radiator must be mounted to and protected by the car's chassis. A cooling system that is drawn through the cockpit must be isolated. The radiator cap must be well protected from impact e.g. if the car rolls-over.

CK-T 3.6 Electrical system

Kill switches that cut the engine's ignition system must exist and may not be of spring type that automatically goes back to start position. If the car has a battery, a master switch must be mounted that cuts all electricity. Both must be easily accessible by the driver when fully strapped in the safety harness as well as for officials. The switch/master switch must be placed on the same side as the engine. They must be well marked with a red lightning bolt on a triangle shaped white bottom with blue lining. The triangle's side must be at least 60 mm and one the edges must point towards the switch (see fig. 9).

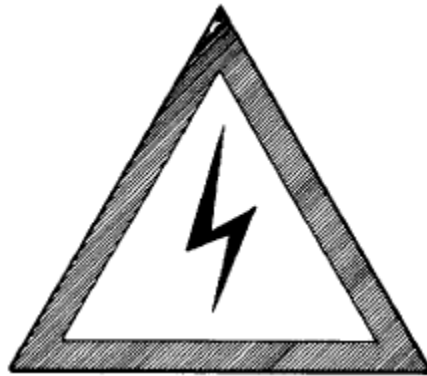

Fig 9. Marking of the master switch's location, (red lightning bolt on white bottom with blue lining) with a 60 mm side.

CK-T 3.7 Power transfer

The power transfer between the engine and the rear wheels must be effected with chain without any intermediate pulleys and sprockets between the engine's pulley and the rear axle's sprocket. Prop shaft /rear axle must solid i.e. manufactured in one-piece and only in material of steel/iron. Other parts mounted on rear axle is free. Hollow axle is aloud

Drives - and chain protection must exist so that injuries are avoided. Gear ratio between engine and rear axle is unrestricted. All kind of electronic system which help prevent wheel spin is not aloud.

CK-T 4 Brake system

CK-T 4.1 Foot brake

The foot brake system may only brake the rear wheels. The system must work efficiently i.e. fast and safely. In every other aspect it is unrestricted. The brake lines and hoses shall be mounted and drawn so that they are not damaged. A handbrake or similar must exist so as to prevent the cross kart rolling on the start line.

Cars of class over 250 cc are eligible to with brakes also on the front wheels. There shall be a hydraulic system with 2 separated circuits, one circuit for the rear wheels and one for the front wheels. Possibilities to adjust the balance between this two circuits is mandatory.

CK-T 5 Steering system

CK-T 5.1 Steering

The steering must be actuated by a steering wheel. In every other aspect the design is free (see CK-T 2.2, fig. 4). The steering must be effective i.e. fast and safely.

CK-T 6 Bodywork

CK-T 6.1 Coverage of chassis / mudguards

The chassis must minimum be covered with sheet metal or plastic material on the upper side in front the driver's seat and on sides between the wheels. Behind the main roll hoop, the roll cage may be covered if necessary openings for rear view exist. Except this the design of body / mudguard is free

The bodywork may extend outside wheels restriction line maximum 200mm as long as total width x length not exceed 1500 x 2500mm. Only part of bodyworks plastic or glasfiber can extend outside, no metal is aloud.

CK-T 6.3 Seat

Must be mounted to the chassis and of bucket type. The seat must allow for a comfortable driving position. The seat must be securely mounted in at least 4 positions without the risk of crevices at mounting points.

CK-T 6.4 Safety harness

See *CK-T 0.4.1*

CK-T 6.5 Safety net

Nets that prevent hands and arms to reach outside the roll cage must exist. The net must be placed between the main roll hoop and the front brace on both of the car's sides. The net must be manufactured of synthetic fibre material. The mesh size may

not exceed 60 mm. A safety net made of steel may be mounted between front braces under during condition that the two braces can be opened without the need to disassemble the net.

CK-T 7 COMMUNICATION

CK-T 7.1 Rear-view mirrors, lamps, windscreen

Are not eligible for cross karts. Also type of transparent view screen, irrespective of material used is prohibited.

CK-T 7.2 Wireless

Any wireless communication between the car / driver and pit / assistants is not allowed during qualification and final heats.

CK-T 8 INSTRUMENTATION

CK-T 8.1 Instrumentation, controls

Rev counter, temperature gauge etc. and controls may be used but must be placed in such a way that no sharp edges can cause unnecessary damage in an accident.

CK-T 9 OTHER

CK-T 9.1 Minimum weight

The minimum weight included the driver is following:

Class 85 - Until 85cc - Minimum 230kg (100kg)

Class 125 - Until 128cc - Minimum 250kg

Class 250 - Until 255cc - Minimum 270kg

Class 650 - Until 460cc - Minimum 275kg

-Until 510cc - Minimum 280kg

-Until 560cc - Minimum 285kg

-Until 610cc - Minimum 290kg

-Until 660cc - Minimum 295kg The minimum weight is defined as the

weight during practise/qualification/competition. The car can be called in for weighing anytime before, during or after practise/qualification/competition and must then meet the requirement. It is not allowed to fill up any fluids to any containers.

Weight in () (85cc class) is weight on the front wheels included driver. Weighing of front wheels shall be done with the car in horizontal position, driver sitting with helmet against headrest, hands on steering wheel and feet behind pedals. When weighing, a tolerance of 1% applies to the weighing machine. The weighing machine at the circuit shall be inspected by the competition management/head of judges.

CK-T9.1.2 Ballast

Possible ballast weights shall preferably be tubes welded into headframe to increase strength. Any other components which is only defined as mounted ballast shall anyway totally not exceed a weight of 20kg

Any ballast weights are required to be solid and uniform and must be mounted to the car's chassis/frame and must be securely fastened ~~with min.6 mm bolts~~ with locknut and designed so that they may be sealed.

CK-T 9.2 Maximum dimensions

The car's maximum dimensions during competition may not exceed a width of more than 1500 mm and a length of more than 2100 mm measured on the wheels' tires/rims outer sides, which is measured on the tires' outer sides. When measuring, the front wheels must be in a position to drive straight forward (see CK-T 1.3 fig. 3 and CK-T 3:1 fig 6).

The bodywork may extend outside wheels restriction line maximum 200mm as long as total width x length not exceed 1500 x 2500mm. Only part of bodyworks plastic or glassfiber can extend outside, no metal is aloud.